

Camry

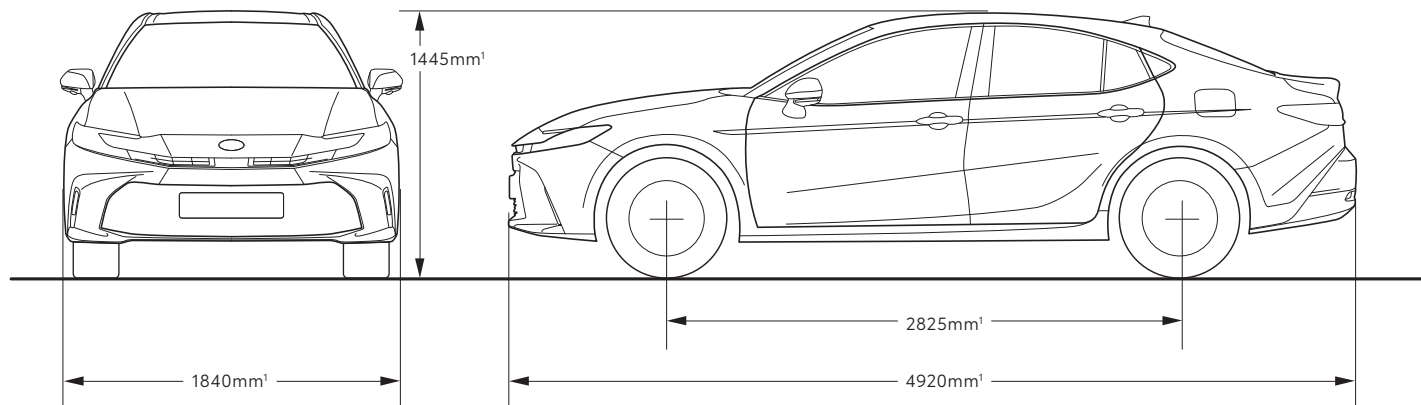

Please Note: information is accurate as at September 2024.

Specification and imagery are indicative and should only be used as a guide. Vehicle and accessory specification, features, colour and trim may differ at the time of vehicle delivery.



MECHANICAL SPECIFICATIONS		Camry	
ENGINE	Engine description	2.5L Dual VVT-i petrol engine with Toyota Hybrid Electric System	
	Engine code	A25A-FXS	
	Max power ² (kW @ rpm)	138 @ 6000	
	Max torque ² (Nm @ rpm)	221 @ 3600-5200	
	Combined maximum power output ² (kW)	170	
	Bore x stroke (mm)	87.50 x 103.48	
	Compression ratio	14.0:1	
FUEL	Fuel type octane no. (Minimum recommended)	95 or higher	
	Fuel economy (L/100km) ³ in laboratory conditions	Combined	4.0
		Extra Urban	4.0
		Urban	4.0
TRANSMISSION	Transmission	Electronic Continuously Variable Transmission (e-CVT)	
	Sports paddle shift	SL grade only	
STEERING	Manual tilt and reach steering wheel adjustment	Ascent and Ascent Sport grades only	
	Power tilt and telescopic steering wheel adjustment	SL grade only	
	Steering type	Electric Power Steering	
BRAKES	Brake type	Front ventilated disc and rear solid disc	
	Park brake	Electronic	
	Braking system	Regenerative-capable	
SUSPENSION	Front suspension	MacPherson strut type	
	Rear suspension	Multi-link type	

CAMRY GRADE		Ascent	Ascent Sport	SL
WEIGHTS AND CAPACITIES (APPROXIMATE)	Vehicle kerb weight (max) (kg) ¹	1565	1565	1625
	Gross vehicle weight (kg) ¹	2100	2100	2100
	Luggage capacity (L)	524	524	524
	Fuel tank capacity (L)	50	50	50
WHEELS	Design and size	17" alloy	17" alloy	18" alloy
	Spare wheel	Temporary		
	Spare wheel tyre size	T155/70D17		
EXTERIOR	Electrically adjustable rear view mirrors with side indicators	•	•	•
	LED Daytime Running Lamps (DRLs)	•	•	•
	Panoramic full glass roof			•
	Front and rear auto power operated windows	•	•	•
	Rain-sensing wipers			•
INTERIOR	Premium steering wheel		•	•
	Seat heating and ventilation for driver and front passenger			•
	Heated steering wheel			•
	Leather accented seats			•
	Stainless steel scuff plates		•	•
	Driver's seat power adjustable lumbar support		•	•
	6-way manual driver's seat adjustment	•		
	8-way power adjustable driver's seat		•	Driver and passenger seat
	Driver's seat memory function			•
	60/40 split fold rear seats	•	•	•
	Folding rear seat centre armrest	•	•	•
STORAGE	Centre console with lid (7.0L)	•	•	•
	Sunglass holder – front overhead console	•	•	•
	Beverage holders x 8 – front centre console, front and rear doors, rear centre armrest	•	•	•
INSTRUMENTS AND CONTROLS	7" Multi Information Display (MID)	•	•	
	12.3" Multi Information Display (MID)			•
	Wireless Apple CarPlay ^{4,5} and Wireless Android Auto ^{TM,4,6}	•	•	•
	Panoramic View Mirror	•	•	•
	Manual headlamp levelling	•	•	•
	12V power accessory socket	•	•	•
	Smart entry and start system	•	•	•
	Nano TM X air conditioning technology			•
	Dual-zone automatic climate control air conditioning	•	•	•
	Front USB-C Audio Jack	•	•	•
	USB-C charging ports – 2 x rear, 2 x front	•	•	•
	Auto-dimming interior rear view mirror			•

CAMRY GRADE		Ascent	Ascent Sport	SL
MULTIMEDIA	8" colour touchscreen display	•		
	12.3" colour touchscreen display		•	•
	Digital Radio	•	•	•
	Bluetooth® ^{7, 8} connectivity	•	•	•
	Voice recognition	•	•	•
	Inbuilt navigation		•	•
	Steering wheel audio controls	•	•	•
SAFETY¹¹	Toyota Safety Sense – including Lane Departure Alert, Pre-Collision Safety System with pedestrian detection, Automatic High Beam, All Speed Active Cruise Control with Road Sign Assist (speed signs only)	•	•	•
	Safe Exit Assist	•	•	•
	Emergency Driver Support System (EDSS)	•	•	•
	Driver Monitor Camera	•	•	•
	Blind Spot Monitor with Rear Cross Traffic Alert	•	•	•
	Anti-lock Braking System with Electronic Brake-force Distribution and Brake Assist	•	•	•
	Vehicle Stability Control and Traction Control	•	•	•
	Hill-start Assist Control and Brake Hold	•	•	•
	Electronically Controlled Brake system	•	•	•
	Reversing camera with moving guidelines	•	•	•
	Front and rear clearance sensors	•	•	•
	8 SRS airbags - dual front, front side, centre, full length curtain airbags and driver's knee airbag	•	•	•
	Child proof locks – rear	•	•	•
SECURITY	Immobiliser with alarm	•	•	•
	Remote central locking including boot release on remote	•	•	•
TOYOTA CONNECTED SERVICES¹⁰	Toyota Connected Services – including Safety and Security features, Driving Insights, Connected Multimedia and Remote Connect – accessible via myToyota Connect app ¹⁰	1 year complimentary access ¹⁰		

1 Weights/mass/volumes/dimensions are approximate and subject to individual vehicle variances, and should be confirmed before fitting any accessories, towing or otherwise relying on this value.
2 Power and torque test standards differ. Ensure comparisons use same test standard.
3 Results achieved for Camry Ascent, Ascent Sport & SL in ADR81/02 combined drive cycle fuel consumption testing. Combined/Extra Urban/Urban cycle results achieved 4.0/100km for Ascent, Ascent Sport & SL. Results produced in laboratory test conditions, using sample vehicles without fitment of accessories/customisation, and do not reflect real world driving. Figures should only be used for comparative purposes.
4 Requires compatible device, USB connection, mobile data, network reception and GPS signal. Mobile usage at user's cost. Apps subject to change. For details see toyota.com.au/connected
5 CarPlay® is a trademark of Apple, Inc. registered in the U.S. and other countries.
6 Android Auto™ is a trademark of Google LLC.
7 Compatibility and functionality varies depending on device.

8 Bluetooth® is a registered trademark of Bluetooth SIG, Inc. Siri® is a trade mark of Apple, Inc. registered in the U.S. and other countries.
9 Google Now™ is a trademark of Google LLC.
10 Complimentary period ends 1 year from delivery date. For eligible TCPO vehicles: Complimentary 6 month period begins from date of activation, or for vehicles subject to an applicable new vehicle Toyota Connected Services complimentary period, at the expiry of that period. Fees may apply thereafter. See toyota.com.au/connected/plans-packages. Not available outside Australia, if services disabled or terminated or after 2033/Telstra 4G sunset.
11 Driver assist feature. Only operates under certain conditions. Check your Owner's Manual for explanation of limitations. Please drive safely.
12 Only Qi-supported devices compatible. Refer to device manufacturer. May require additional purchase of accessory to support wireless charging.