

bZ4X

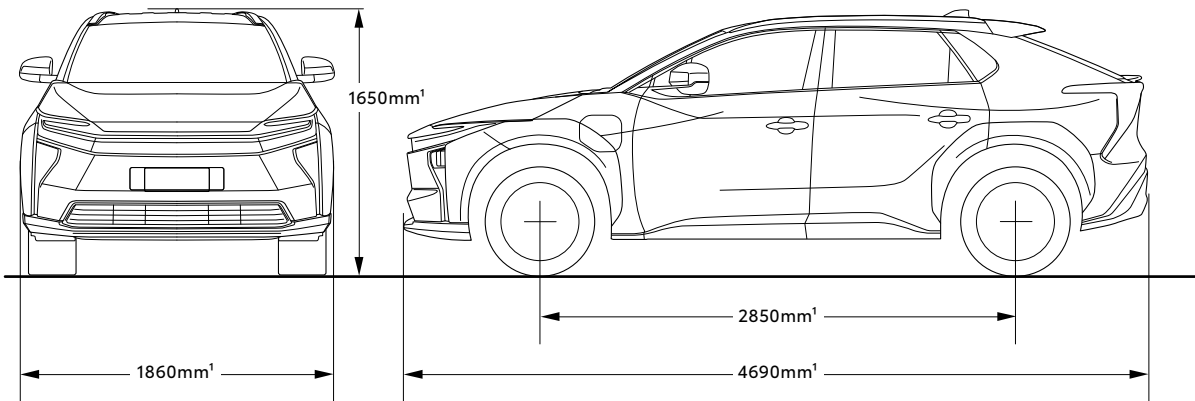

Please Note: information is accurate as at June 2026.

Specification and imagery are indicative and should only be used as a guide. Vehicle and accessory specification, features, colour and trim may differ at the time of vehicle delivery.



MECHANICAL SPECIFICATIONS		bZ4X 2WD	bZ4X AWD	
ELECTRIC MOTOR	Type	Permanent Magnet Synchronous Motor		
	Maximum (kW)	Front motor	167	167
		Rear motor		88
	Model code front/rear	2XM / -	2XM / 3XM	
	Max torque (Nm)	Front	268.6	268.6
Rear			169.8	
BATTERY AND CHARGING	Battery type	Lithium-ion battery		
	Battery capacity (Ahr)	191		
	Number of battery cells	104		
	Voltage per cell	3.76		
	Total voltage (V)	391		
	Traction battery capacity (Ahr)	191		
	Total power (kWh)	74.7		
	Mode 2 and Mode 3 charging cables	Included		
	AC charging² – 10-100%	7kW Single-Phase Charging	approx. 9 hours 30 mins	
		11kW 3-Phase Charging	approx. 7 hours	
		22kW 3-Phase Charging	approx. 3 hours 30 mins	
	150 kW DC Charging² – 10-80%	approx. 45 mins		
	AC Input – standard	Type 2		
	DC Input – quick charge	CCS2		
Max AC charging power (kW)	22			
DC charger maximum output (kW)	150			
STEERING	Gear type	Rack and Pinion		
	Type	Electric Power Steering		
	Overall gear ratio	14.2		
	Lock to lock	2.81		
SUSPENSION	Front	MacPherson strut		
	Rear	Double wishbone		
	Stabilizer bar – front and rear	Torsion bar		
BRAKES	Type – front and rear	Ventilated disc brake		
	Front diameter (mm)	328		
	Rear diameter (mm)	317		
	Regenerative braking system with paddle control	•		

bZ4X GRADE		bZ4X	bZ4X AWD
DRIVETRAIN AND TRANSMISSION	Transaxle model code (Front/Rear)	QK10 / -	QK10 / QM10
	Total speed reduction ratio (Front/Rear)	13.817 / -	13.817 / 13.754
	Front wheel drive	•	
	All wheel drive		•
	Type	BEV automatic transmission	
WEIGHTS AND CAPACITIES (APPROXIMATE)	Seating capacity – persons	5	5
	Cargo space (L)	452	452
	Gross vehicle weight ¹ (kg)	2465	2560
	Maximum curb weight ¹ (kg)	1905	2035
	Running ground clearance ³ (mm)	212	212
	Towing capacity ⁴ (kg)	750 (Max Towing Capacity)	1500 (Braked Towing Capacity)
WHEELS	Design and size	18" Alloy wheels with aero covers	20" Alloy wheels with aero inserts
	Tyre repair kit	•	•
PERFORMANCE	Maximum speed (km/h)	160	160
	Acceleration 0 to 100km/h	7.4	5.1
	Minimum turning radius (m)	Tyre = 5.6 / Body = 6.1	
	BEV driving test range ^{5,6} (km) – Actual driving range can be significantly less than test driving range, depending on various factors	591km (WLTP) ^{5,6}	517km (WLTP) ^{5,6}
	Electric energy consumption ^{5,6} (Wh/km)	138Wh/km (WLTP) ^{5,6}	160Wh/km (WLTP) ^{5,6}
COMFORT AND CONVENIENCE	Dual-zone climate control auto air conditioning	•	•
	Nanoe™ ⁷ X air conditioning technology	•	•
	Rear air vents	•	•
	Electric park brake	•	•
	Automatic rain sensing wipers	•	•
	Key Reminder Alert	•	•
	Driver power passenger front seat – 8-way	•	With memory
	Heated front seats – driver and passenger	•	•
	Ventilated seats – driver and passenger		•
	Cupholders – 2x front, 2x rear	•	•
EXTERIOR	LED Daytime Running Lamps	•	•
	Heated exterior mirrors with puddle lights	•	With memory and reverse auto adjust
	Headlamp cleaner	•	•
	LED headlamps	•	•
	LED rear and eye level brake lights	•	•
	LED side mirror indicators	•	•
	Rear fog lamps	•	•
	Rear, side, quarter and back privacy glass	•	•
	Roof rails	•	•
	Rear spoiler		•
	Front and rear air spats	•	•
	Gloss black wheel arches and bonnet insert	•	•
	Two-tone roof		Optional

bZ4X GRADE		bZ4X	bZ4X AWD
INSTRUMENTS AND CONTROLS	Intelligent parking assist ⁸		•
	7" colour Multi Information Display (MID)	•	•
	Rear view mirror	Auto-dimming rear view mirror	Digital rear view mirror
	Auto retractable door mirrors	•	•
	Power back door with kick sensor	•	•
	Heated steering wheel, audio, phone, MID, and Toyota Safety Sense controls	•	•
	12V socket	•	•
	Smart entry and smart start	•	•
	2x USB-C Ports (Front) in centre console storage	•	•
	2x USB-C Ports in rear centre console	•	•
	2x wireless phone chargers ⁹	•	•
	Voice assistant	•	•
	Vehicle Stability Control	•	•
	Downhill Assist Control, Multi Terrain Sensing and Crawl Control ⁸		Accessible through X-Mode
	3 off-road modes (X-Mode)		•
Tilt and telescopic steering wheel adjustment	•	•	
INTERIOR	Vehicle-to-Load (V2L) ¹⁰ – AC Inverter 220V/1500W	•	•
	Centre tray	•	•
	Interior seat trim	Fabric and SofTex ^{®7}	Premium SofTex ^{®7}
	Rotary dial shift with integrated park brake	•	•
	60:40 folding rear seats	•	•
	Personal front LED reading lamp	•	•
	Luggage compartment light	•	•
	Fixed panoramic moon roof		•
MULTIMEDIA	6x speakers	•	
	9-speaker JBL ⁷ premium sound system		•
	14" multimedia system with embedded navigation	•	•
	Digital Audio Broadcast	•	•
	Wireless Apple CarPlay ^{®11} and Wireless Android Auto ^{™11}	•	•

bZ4X GRADE		bZ4X	bZ4X AWD
SAFETY AND SECURITY	8x SRS Airbags	•	•
	Toyota Safety Sense ⁸ – including Dynamic Radar Cruise Control, Lane Trace Assist, Pre-Collision Safety system with pedestrian and daylight cyclist detection and Intersection Collision Avoidance Support, Emergency Steering Assist, Blind Spot Monitor and Safe Exit Assist, Road Sign Assist (speed signs only), Adaptive High Beam System and Emergency Driving Stop System	•	•
	Rear Cross Traffic Alert ⁸	•	•
	Driver monitor camera ⁸	•	•
	Panoramic View Monitor ⁸	•	•
	Parking Support Brake with parking sensors ⁸	•	•
	Anti-lock Braking System with Electronic Brake-force Distribution and Brake Assist ⁸	•	•
	Rear seat occupant reminder	•	•
	Seatbelt reminder – all seats	•	•
	2x ISOFIX child restraint anchorage points – rear outboard seats	•	•
	First Aid kit	•	•
TOYOTA CONNECTED SERVICES ^{12,13,14}	Toyota Essentials Emergency	Complimentary until Telstra 4G sunset or termination of services in accordance with our T&Cs	
	Toyota Essentials	Complimentary until Telstra 4G sunset or termination of services in accordance with our T&Cs	
	Toyota Connect+	1 year complimentary access – Fees apply thereafter. Subject to Telstra 4G sunset or termination of services in accordance with our T&Cs	
	Toyota Connected Multimedia	1 year complimentary access – Fees apply thereafter. Subject to Telstra 4G sunset or termination of services in accordance with our T&Cs	

- Weights/mass/volumes/dimensions are approximate and subject to individual vehicle variances, and should be confirmed before fitting any accessories, towing or otherwise relying on this value.
- Charging times are indicative only and may vary depending on environmental and charging conditions, type of charger and method used. Actual charging times may differ. Frequent use of DC fast charging can impact battery performance and durability. Toyota recommends minimising DC fast charging usage. DC fast charging speed will reduce after the battery is charged to 80%. Refer to Owner's manual and toyota.com.au/explore/electrified/charging-your-toyota for guidance.
- Dimensions are approximate and are subject to individual vehicle variances, accessory fitment and weight carried.
- Fitment of towbar requires deactivation of the kick boot sensor feature. Towing capacity subject to regulatory requirements, tow bar and vehicle design and towing equipment limitations. Ask your Dealer for Toyota Genuine tow bar capacity and availability details.
- Results were achieved under test conditions and do not reflect the driving range in real world driving. Results achieved for battery electric bZ4X Electric SUV is based on consumption rate of 138 Wh/km using the Worldwide Harmonised Light Vehicle Test Procedure (WLTP) accepted by the ADR 81/02 (displayed on the Energy Consumption label affixed to the car). The electric range and the energy consumption values were determined using a fully charged battery in a laboratory test and are not reflective of real world driving. Actual driving range may vary depending on accessories fitted, battery age and condition, climate, driving style, use of heating/cooling, traffic conditions, and vehicle load. For more information, please visit toyota.com.au/explore/electrified/faqs
- Results were achieved under test conditions and do not reflect the driving range in real world driving. Results achieved for battery electric bZ4X AWD Electric SUV is based on consumption rate of 160 Wh/km using the Worldwide Harmonised Light Vehicle Test Procedure (WLTP) accepted by the ADR 81/02 (displayed on the Energy Consumption label affixed to the car). The electric range and the energy consumption values were determined using a fully charged battery in a laboratory test and are not reflective of real world driving. Actual driving range may vary depending on accessories fitted, battery age and condition, climate, driving style, use of heating/cooling, traffic conditions, and vehicle load. For more information, please visit toyota.com.au/explore/electrified/faqs

- Product and company names are trademarks of their respective owners.
- Driver assist feature. Only operates under certain conditions. Check your Owner's Manual for explanation of limitations. Please drive safely.
- Only Qi-supported devices compatible. Refer to device manufacturer. May require additional purchase of accessory to support wireless charging.
- Vehicle to Load (V2L) supports electrical devices with a combined power consumption of up to 1500W at 220 VAC. V2L does not support Vehicle to Home (V2H) or Vehicle to Grid (V2G) charging. V2L is powered using the high voltage battery and extended use will decrease driving range. Never leave the vehicle unattended when using the V2L system. Refer to Owner's Manual for guidance.
- CarPlay[®] is a trademark of Apple, Inc. registered in the U.S. and other countries. Android Auto[™] is a trademark of Google LLC.
- See toyota.com.au/services/connected/terms-conditions for T&Cs.
- Complimentary periods commence upon delivery date. Fees may apply there after. Not available outside Australia, if services disabled or terminated or after Telstra 4G sunset. Dependent on enabled DCM, GPS signal strength, mobile network coverage, mobile app data (at user's cost), enabled push notifications and other factors outside Toyota's control which can limit ability or functionality of system. Check your Owner's Manual or toyota.com.au/services/connected for explanation of limitations. Please drive safely.
- The myToyota Connect App supports vehicles with a Build date from 2009 onwards, with or without Toyota Connected Services. Requires compatible device and app installation, mobile data (at user's cost), Australian network reception, GPS signal, enabled push notifications and other factors outside Toyota's control which can limit functionality. Features vary by model and may change. See toyota.com.au/services/connected for more information.

IMPORTANT NOTICE – PLEASE READ: Toyota Australia uses its best endeavours to ensure material is accurate at the time of publishing. All information must be confirmed with your Toyota Dealer at the time of ordering, as specifications, applicability and availability may change over time. Colours depicted are a guide only and may vary from actual colours due to the printing/display process. Toyota Australia reserves the right to change and/or discontinue, without notice, models, prices, colours, materials, equipment, specifications. To the extent permitted by law, Toyota Australia will not be liable

for any damage or loss incurred from relying on the information and images contained in this material. Distributed nationally (other than in Western Australia) by Toyota Motor Corporation Australia Limited ABN 64 009 686 097. Material distributed in Western Australia by or on behalf of Prestige Motors Pty Ltd (for vehicles) and by Eastpoint Pty Ltd (for parts/accessories). Toyota Australia makes no warranties regarding (and will not be liable for) accuracy of materials distributed in Western Australia. PROOF HQ: T2026-023314. GTP-010030. VERSION: JUNE 2026.